



## BOY > RACER > ART >

For the last few years there has for obvious reasons been an increasing fascination with the changing pace of Modern-day life, most notably perhaps with the exhibitions *Rapid - Artpace, Auckland and Dunedin Public Art Gallery, Dunedin, 1997 - Speed - Whitechapel and the Photographers Gallery, London, 1998* - and most recently, *Drive - Govett-Brewster Art Gallery, New Plymouth, 2000*. Large, comprehensive and thorough documents of the 20th Century, these shows however seem to have quickly missed the point, or be completely oblivious to (or perhaps too scared to acknowledge) the real driving force of modernity as it races past. Ambling slowly down the middle of the road, looking over their shoulders and watching the scenery out of the window, no one has noticed the New Futurists as they speed on by. Whilst some prefer to wax philosophical about our love affair with the Automobile and the Information Superhighway, boy racers, motorheads and garage geeks are still cruising the main.



### Vaughan Gunson

1. Suspended  
AA pamphlets in string bag and nylon rope

### Scott Everson

2. Untitled (so you wanna be a boy racer)  
Looped sound of Nascar racing, racing helmet, customized plinth

3. Untitled  
Drawing on paper

4. Untitled  
Painted kitset model cars and key-chains

5. Untitled  
Drawing on paper

### Good Kunst

6. Untitled (Jackson Pollock)  
Customized kitset model car

### Tim Checkley and Cat Chapman

7. Marked for Death  
Claymation video

### Lauren Winstone

8. Big Wheel Cap  
Embroidered caps
9. Big Wheel Key Ring  
Custom key-chains

10. Looking for a Big Wheel  
Video

### Tim Doe and Nicholas Spratt

11. Untitled (2 player battle)  
Video

### Victoria Munro

12. Back Seat Driver  
Photograph of butt press with zip

### Steve Carr

13. Custom Muffler (Ltd Edition)  
Custom muffler on revolving plinth

### Dane Mitchell

14. Bad One-Liner  
Shit coloured paint on Jockey y-fronts

Not pictured

### Clinton Watkins and Jayren Dixon

Selected works from the Giant Bastard and Baby Rapper hip hop collection

The Drivers was curated by Nicholas Spratt and exhibited at the Physics Room from May 3 - May 28, 2000.

A catalogue featuring essays by B.K. Anderson and Phil Chard and sound work by Scott Everson, Steve Carr, Clinton Watkins and Jayren Dixon is available from the Physics Room.

## Vaughan Gunson



1

## Good Kunst

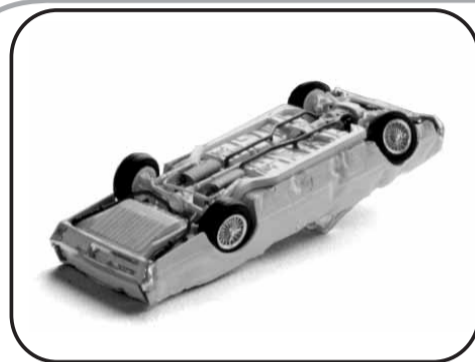

6

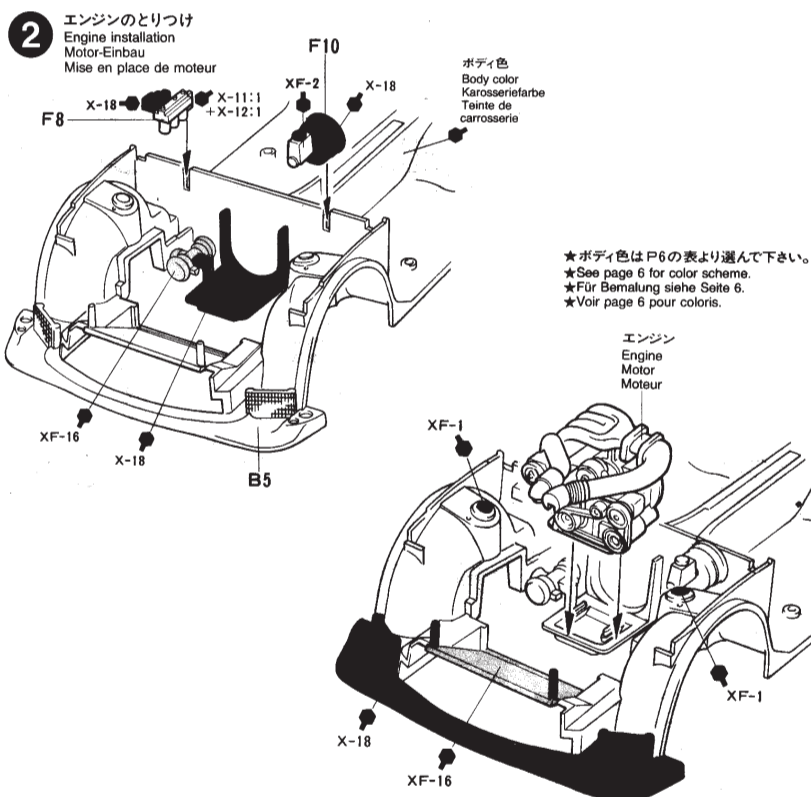

## Victoria Munro



12

## Steve Carr



13

# Scott Everson



②



③



④

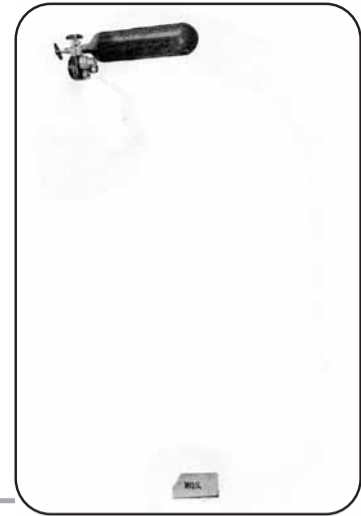

⑤

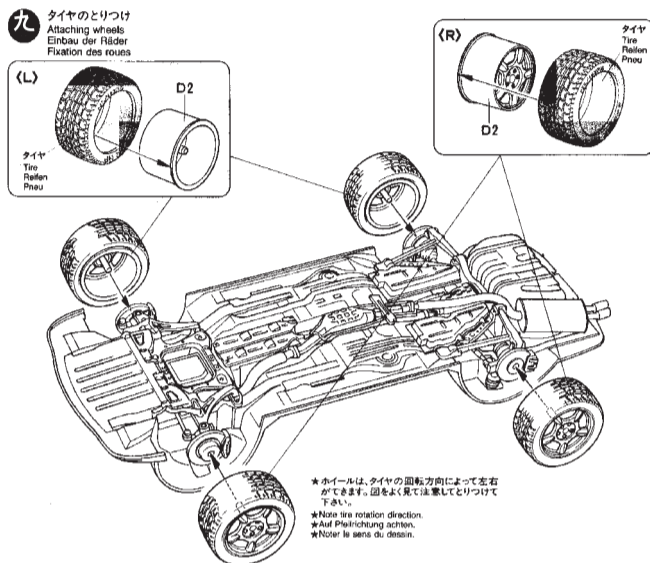

⑦

Tim Checkley and Cat Chapman

⑧



⑨



⑩

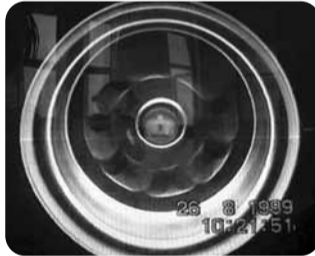

Tim Doe and Nicholas Spratt ⑪



Lauren Winstone

ボディ色 ● C9  
Body color  
Karosseriefarbe  
Teinte de carrosserie

不要部品  
Parts not used.  
Nicht verwenden.  
Non utilisé.  
A2, A4, A5  
B3, C2, C4

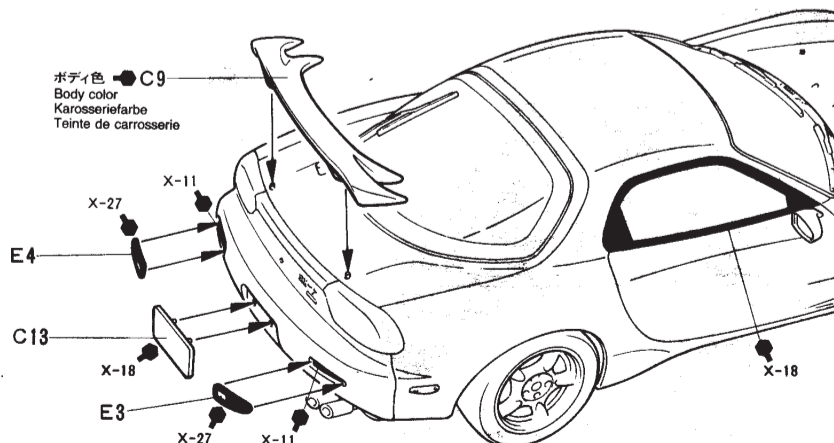

# Dane Mitchell



⑭